

# Transition Metal Polyhydride Complexes. 7. Classical and Nonclassical Structures of $[\text{ReH}_4(\text{CO})(\text{PR}_3)_3]^+$

Zhenyang Lin and Michael B. Hall\*

Contribution from the Department of Chemistry, Texas A&M University, College Station, Texas 77843-3255

Received December 1, 1993. Revised Manuscript Received March 7, 1994\*

**Abstract:** The stabilities of different structures for  $[\text{ReH}_4(\text{CO})(\text{PH}_3)_3]^+$  are predicted from *ab initio* calculations at the MP2 level with effective core potential, split-valence basis sets. Two structures have been found to be of almost equal energy. One has a dodecahedral geometry (**1**) with the four hydride ligands occupying the B sites, and the other has a pentagonal-bipyramidal geometry (**2**) with one  $\eta^2\text{-H}_2$  ligand. These two structures represent the classical and nonclassical tautomers observed experimentally in a solution of  $[\text{ReH}_4(\text{CO})(\text{PMe}_2\text{Ph})_3][\text{BF}_4]$ . The hydride–hydrogen site exchange in the nonclassical structure (**2**) and the interconversion process between **1** and **2** have also been studied. The interconversion was found to be faster (calc barrier 4 kcal/mol) than the site exchange process (calc barrier >8 kcal/mol). From these calculations, we proposed a new interpretation of the NMR experiments. The different chemistry observed for  $[\text{ReH}_4(\text{PMe}_2\text{Ph})_4]^+$  is explained by the interaction of metal d orbitals with the CO  $\pi^*$  orbitals.

## Introduction

Extensive studies of transition metal polyhydride complexes have led to the conclusion that polyhydrides may adopt both classical structures having terminal hydride ligands or nonclassical structures containing  $\eta^2\text{-H}_2$  ligands.<sup>1</sup> Recently, Luo and Crabtree<sup>2</sup> reported that protonation of  $\text{ReH}_3(\text{CO})(\text{PMe}_2\text{Ph})_3$  resulted in an equilibrium mixture of the classical hydride,  $[\text{Re}(\text{H})_4(\text{CO})(\text{PMe}_2\text{Ph})_3]^+$ , and its nonclassical structure,  $[\text{Re}(\text{H})_2(\eta^2\text{-H}_2)(\text{CO})(\text{PMe}_2\text{Ph})_3]^+$ . On the basis of NMR studies, they proposed two structures, a dodecahedron (**1**) and a pentagonal-bipyramid (**5**), for the classical and nonclassical structures, respectively. In their NMR studies, Luo and Crabtree also found a site exchange of dihydrogen and hydride ligands in the nonclassical structure. This hydride–hydrogen site exchange in the nonclassical structure was found to be much faster (with a free energy of activation,  $\Delta G^\ddagger$ , of 9.9 kcal/mol) than the interconversion process of the classical and nonclassical structures ( $\Delta G^\ddagger = 12.2$  kcal/mol). Interestingly, the closely related  $\text{ReH}_3(\text{PMe}_2\text{Ph})_3$  complex only gives a classical tetrahydride upon protonation.<sup>3</sup>

In this paper, we will examine theoretically the stabilities of the two proposed structures for the  $[\text{ReH}_4(\text{CO})(\text{PMe}_2\text{Ph})_3]^+$  complex together with several other possible structures (see Figure 1), and we will discuss the mechanisms involving the site exchange of hydrogens.

## Theoretical Details

In a series of theoretical studies,<sup>4</sup> we concluded that the second-order Møller–Plesset (MP2) perturbation calculations provide reliable results to determine the relative stabilities of classical and nonclassical structures. All geometries in Figure 1 were optimized at the MP2 level. We replaced  $\text{PMe}_2\text{Ph}$  by  $\text{PH}_3$  where

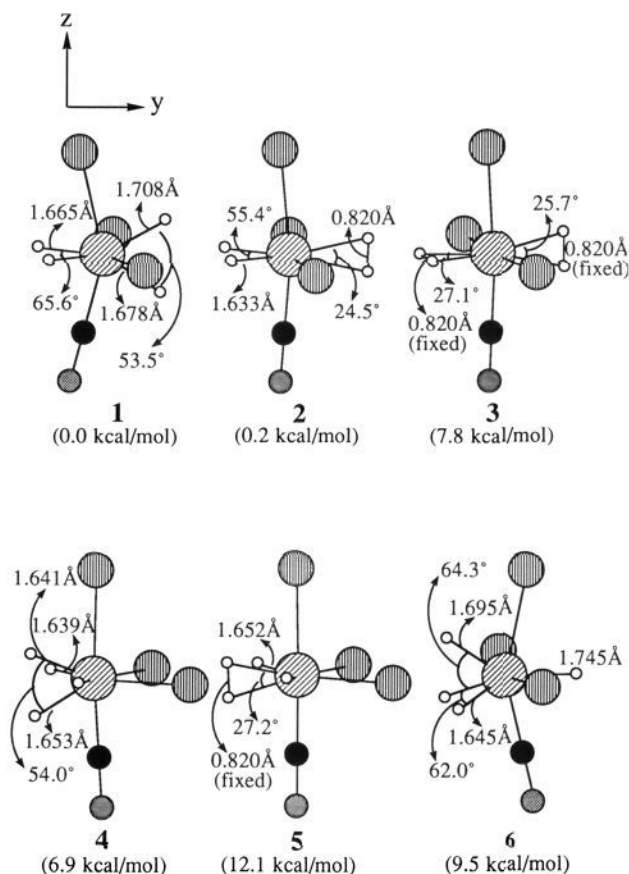

**Figure 1.** The relative energies and selected calculated structural parameters for different structures of the  $[\text{ReH}_4(\text{CO})(\text{PH}_3)_3]^+$  complex. All geometries have  $C_s$  symmetry.

the P–H bond distance was fixed at 1.44 Å and the Re–P–H bond angle at 115°, and we fixed the Re–C–O angle at 180°. Except as noted below, all other geometric parameters were optimized. The effective core potential (ECP) and basis set, (541/41/111), of Hay and Wadt<sup>5</sup> were employed for the Re atom. For ligand atoms, the ECPs and basis sets with a double- $\zeta$  representation of

(5) Hay, P. J.; Wadt, W. R. *J. Chem. Phys.* 1985, 82, 299.

\* Abstract published in *Advance ACS Abstracts*, May 1, 1994.

(1) (a) Kubas, G. J. *Acc. Chem. Res.* 1988, 21, 120. (b) Crabtree, R. H. *Chem. Rev.* 1985, 85, 245. (c) Crabtree, R. H. *Acc. Chem. Res.* 1990, 23, 95.

(2) (a) Luo, X. L.; Crabtree, R. H. *J. Chem. Soc., Chem. Commun.* 1990, 189. (b) Luo, X. L.; Crabtree, R. H. *J. Am. Chem. Soc.* 1990, 112, 6912.

(3) Lunder, D. M.; Green, M. A.; Streib, W. E.; Caulton, K. G. *Inorg. Chem.* 1989, 28, 4527.

(4) (a) Part 1: Lin, Z.; Hall, M. B. *Inorg. Chem.* 1991, 30, 2569. (b) Part 2: Lin, Z.; Hall, M. B. *J. Am. Chem. Soc.* 1992, 114, 2928. (c) Part 3: Lin, Z.; Hall, M. B. *J. Am. Chem. Soc.* 1992, 114, 6574. (d) Part 4: Lin, Z.; Hall, M. B. *Inorg. Chem.* 1992, 31, 4262. (e) Part 5: Lin, Z.; Hall, M. B. *Organometallic* 1992, 11, 3801. (f) Part 6: Lin, Z.; Hall, M. B. *Organometallic* 1993, 12, 4046.

## Scheme 1

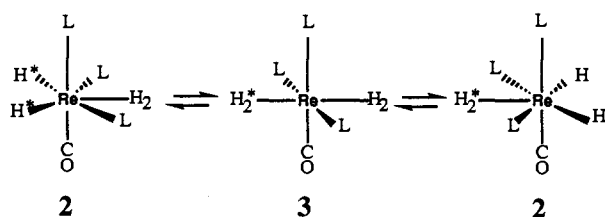

Stevens, Basch, and Krauss were used.<sup>6</sup> The Dunning-Huzinaga<sup>7</sup> double- $\zeta$  basis set (31) was used for the H atom. All ab initio calculations were performed with the Gaussian 92 software,<sup>8</sup> at the Supercomputer Center of Cray Research, Inc., MN, on a Cray YMP-M98-4Gw-8.

In our previous work<sup>4b</sup> we compared the effects of replacing  $\text{PH}_3$  ligands with the more realistic  $\text{PMe}_3$  ligand and of increasing both the basis set and the level of perturbation theory. On the basis of this work we can estimate that the combined improvements would stabilize the classical structures over the nonclassical structures by 3–6 kcal/mol. Also, larger phosphines will destabilize structures with close phosphine contacts by several kilocalories per mole. The interpretation presented below would not be materially affected by these remaining errors.

## Results and Discussion

**Classical and Nonclassical Structures.** The relative energies of different structures for the  $[\text{ReH}_4(\text{CO})(\text{PH}_3)_3]^+$  complex are shown in Figure 1. We can see that structures 1 and 2 are the two most stable geometries. While structures 4 and 6 are also stationary points on the potential energy surface, structures 3 and 5 are not. To obtain these latter two structures, we fixed pairs of hydrogens to be 0.82 Å apart based on the calculated distance in structure 2. Structure 5, even if it existed, would be 12.1 kcal/mol higher in energy than structure 1. This result, apparently, differs from the previous interpretation of NMR experimental results in which 1 and 5 were proposed to be the two most stable structures. Because of their high energy, structures 3, 4, and 6 can also be eliminated as possibilities for the structures observed in the equilibrium mixture of  $[\text{ReH}_4(\text{CO})(\text{PR}_3)_4]^+$ . Furthermore, structure 3 is not a stationary point and the energy of structure 4 is expected to be even higher when the bulky phosphine ligands are present due to greater ligand–ligand repulsions of the three adjacent phosphine ligands.

**Interconversion and Site Exchange Processes.** We also estimated the activation energy of the interconversion between the classical (1) and nonclassical (2) tautomers by calculating a hypothetical intermediate structure halfway between 1 and 2. The result gave about 4.0 kcal/mol for this barrier. Structure 3 is very likely to be near a transition state for the hydride–hydrogen site exchange process in nonclassical structure 2 through a mechanism shown in Scheme 1. This process is, therefore, a higher energy process with about 7.8 kcal/mol of activation energy. In the original paper,<sup>2</sup> inequivalent diastereotopic methyl groups of the equatorial  $\text{PMe}_2\text{Ph}$  ligands were observed up to 263 K in the rapid hydride–hydrogen site exchange process in the nonclassical structure, and therefore, Scheme 1 was excluded. The exclusion was apparently based on the reasonable assumption that the hydride–hydrogen site exchange process in the nonclassical structure occurs as a lower energy process. However, the lower energy process, in fact, involves the interchange of 1 and

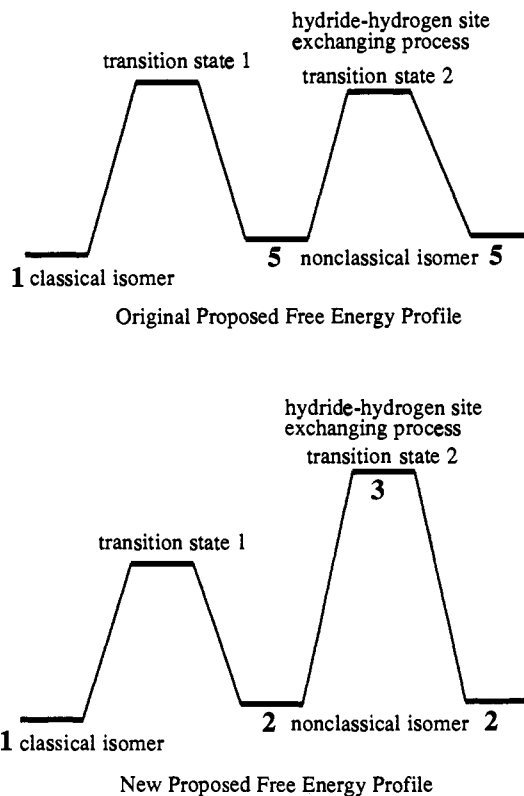

Figure 2. Original and new proposed free energy profiles for the interconversion process between the classical and nonclassical structures in a solution of  $[\text{ReH}_4(\text{CO})(\text{PH}_3)_3]^+$  complex and for the hydride–hydrogen site exchange in the nonclassical structure.

2, and therefore maintains the inequivalent diastereotopic methyl groups of the equatorial  $\text{PMe}_2\text{Ph}$  ligands below 263 K.

An energy profile shown in the bottom part of Figure 2 summarizes the two processes where the hydride–hydrogen site exchange in nonclassical structure 2 is a higher energy process. This result requires a reinterpretation of the previous NMR assignments,<sup>2</sup> which will be summarized briefly below.

**NMR Results and Original Assignments.** Before continuing our discussion, we schematically present in Figure 3 the observed variable-temperature NMR spectra for the  $[\text{ReH}_4(\text{CO})(\text{PH}_3)_3]^+$  system. Below 193 K, three peaks were observed. The quartet hydride resonance was assigned to the four hydride ligands in 1 coupling to the three phosphine ligands. The triplet resonance was assigned to the two hydride ligands in nonclassical structure 5 while the singlet was assigned to the  $\eta^2\text{-H}_2$  ligand. On warming to 213 K, the terminal hydride and  $\eta^2\text{-H}_2$  resonances coalesce into a single broad peak due to their exchange. The quartet becomes one broad peak at 258 K. On further warming to 278 K, the intermolecular exchange between the classical and nonclassical structures is so fast that only an average peak was observed. On the basis of these observations, the free energy profile shown in the top of Figure 2 was originally proposed to illustrate the interchanging processes.<sup>2</sup>

**Reinterpretation of NMR Results.** Apparently, the theoretical calculations support neither the original proposed structure for the nonclassical isomer nor the suggested mechanism of the hydride–hydrogen site exchange in the nonclassical isomer. Therefore, we attempt to reinterpret the experimental results of NMR spectra so that our theoretical results will be consistent with the experimental results. In the bottom part of Figure 3, we reassign the quartet resonance to two of the four hydride ligands in 1 and the two hydride ligands in 2 because of their similar electronic environments. The remaining two hydride ligands in 1 are assigned to the triplet and the  $\eta^2\text{-H}_2$  is assigned to the singlet at 193 K (see the bottom part of Figure 3).

(6) Stevens, W. J.; Basch, H.; Krauss, M. *J. Chem. Phys.* **1984**, *81*, 6026.

(7) (a) Huzinaga, S. *J. Chem. Phys.* **1965**, *42*, 1293. (b) Dunning, T. H., Jr. *J. Chem. Phys.* **1970**, *53*, 2823.

(8) Frisch, M. J.; Trucks, G. W.; Head-Gordon, M.; Gill, P. M. W.; Wong, M. W.; Foresman, J. B.; Johnson, B. G.; Schlegel, H. B.; Robb, M. A.; Replogle, E. S.; Gomperts, R.; Andres, J. L.; Raghavachari, K.; Binkley, J. S.; Gonzalez, C.; Martin, R. L.; Fox, D. J.; Defrees, D. J.; Baker, J.; Stewart, J. J. P.; Pople, J. A. *Gaussian 92*, Revision B., Gaussian, Inc.: Pittsburg, PA.

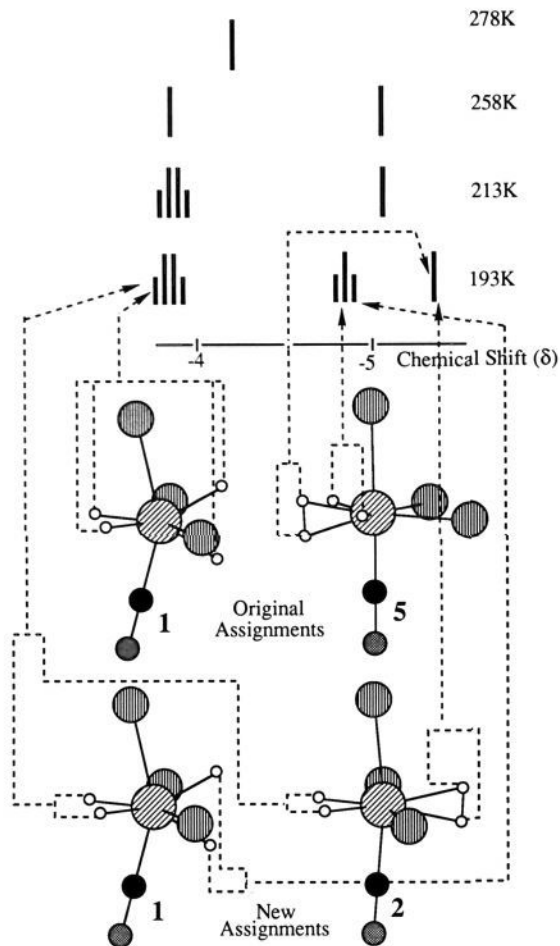

**Figure 3.** Schematic illustration of the original and new assignments of experimental NMR Chemical shifts.

Therefore, on warming to 213 K, the interconversion between **1** and **2** occurs rapidly and the two hydride ligands in **1** (involved in the interconversion) and the  $\eta^2\text{-H}_2$  ligand become indistinguishable. As a result of this rapid interconversion, the triplet and singlet (assigned to the  $\eta^2\text{-H}_2$  ligand) peaks coalesce into one broad peak. On warming further to 258 K, the remaining two hydrides begin to rapidly move between structures **2** and **3** with loss of the coupling to phosphines, but without rotations of the dihydrogen ligands and without inversions of the equatorial phosphine ligands. At this point, the inequivalence of the diastereotopic methyl groups in the equatorial phosphine ligands is preserved and the quartet becomes a singlet. At even higher temperature, the dihydrogen ligands begin to rotate and the phosphine ligands begin to invert according to Scheme 1. Thus, the H resonances become a singlet and diastereotopic splitting

is lost. Our calculations indicate that rotations of these  $\eta^2\text{-H}_2$  ligands in a structure like **3** require an additional 2–3 kcal/mol of activation energy.

**Behavior of  $[\text{ReH}_4(\text{PMe}_2\text{Ph})_4]^+$ .** To understand the different behavior of  $[\text{ReH}_4(\text{CO})(\text{PMe}_2\text{Ph})_3]^+$  and  $[\text{ReH}_4(\text{PMe}_2\text{Ph})_4]^+$ —the latter exists only as the classical isomer—we cite our previous calculations here on three structures of the model complex  $[\text{ReH}_4(\text{PH}_3)_4]^+$ .<sup>4c</sup> The geometries of these three structures are derived from **1**, **2**, and **3** by replacing CO with  $\text{PH}_3$ . We assign them as **1'**, **2'**, and **3'**, respectively. The relative energies are **1'** (0.00 kcal/mol), **2'** (17.4 kcal/mol), and **3'** (26.7 kcal/mol). Comparing these results with those of the first three structures in Figure 1, we find that the substitution of  $\text{PH}_3$  by a CO ligand stabilizes both nonclassical structures **2** and **3** by about 17.0 kcal/mol. This stabilization leads to the observed equilibrium mixture of classical (**1**) and nonclassical (**2**) structures in solution.<sup>2</sup> Interestingly, the stabilization energies for **2** and **3** (compared to **2'** and **3'**) are almost equal. This result can be understood from a simple molecular orbital argument. For a dodecahedral  $\text{ML}_8$  complex (see also **1**), there is only one d orbital which can be stabilized by  $\text{CO } \pi^*$  accepting orbitals. This d orbital, in the case of structure **1**, is  $d_{xz}$  (see Figure 1 for the Cartesian coordinate system). For a pentagonal-bipyramidal complex, like **2**, two d orbitals ( $d_{xz}$  and  $d_{yz}$ ) are available for  $d-\pi^*$  overlaps when the CO ligand is occupying one of the two axial positions. For an octahedral complex, like **3**, two of three d orbitals overlap with  $\text{CO } \pi^*$  orbitals in a fashion similar to that for a pentagonal-bipyramidal complex. Therefore, compared to the dodecahedral structure **1**, structures **2** and **3** should have roughly an equal amount of stabilization energy through the  $d-\pi^*$  CO interaction.

## Conclusion

From the results of these calculations, we propose a new interpretation of the NMR experiments. Structures **1** and **2** rather than **1** and **5** are in the equilibrium mixture observed experimentally. Scheme 1 involving the formation of bis-dihydrogen structure **3** is the mechanism of hydride–hydrogen site exchange in nonclassical structure **2**, but this process occurs only at 263 K or above. Because of this new interpretation, postulating the formation of a  $\eta^3\text{-H}_3$  species in the site exchange process becomes unnecessary. The difference in the chemistry of  $[\text{ReH}_4(\text{CO})(\text{PMe}_2\text{Ph})_3]^+$  and  $[\text{ReH}_4(\text{PMe}_2\text{Ph})_4]^+$  is explained with a simple molecular orbital argument which emphasizes the ability of the CO ligand to stabilize two and only two metal d orbitals.

**Acknowledgment.** We thank the National Science Foundation (Grant No. CHE 91-13634) and the Robert A. Welch Foundation (Grant No. A-648) for financial support. We also thank Chris Hempel and Cray Research Inc. for providing the opportunity of using the Cray YMP-M98-4Gw-8. The authors thank R. H. Crabtree, J. W. Faller, and K. W. Zilm for helpful discussions.